

SIGN FOR AREAS THAT IRRIGATE WITH RECLAIMED WATER

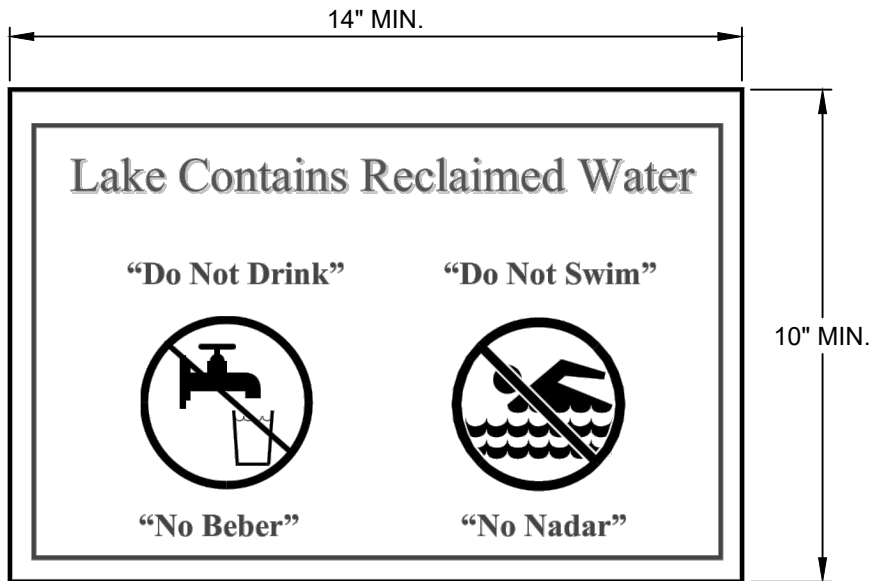

SIGN FOR STORAGE LAKES/PONDS THAT USE RECLAIMED WATER

NOTE:

1. SIGNS SHALL COMPLY WITH RULE 62-610.468, F.A.C.
2. SIGN MATERIAL SHALL BE 14 GAUGE ANODIZED ALUMINUM.
3. BACKGROUND OF SIGN SHALL BE PURPLE (PANTONE 522C).
4. BORDER, LETTERS, AND SYMBOLS SHALL BE WHITE.
5. ALL TEXT SHALL BE HELVETICA.
6. SIGN SUPPORTS SHALL BE INSTALLED IN ACCORDANCE WITH FDOT STANDARD PLANS, INDEX 700. THE CLEARANCE FROM THE BOTTOM OF THE SIGN SHALL TO FINISHED GRADE SHALL BE 4'-0" MIN.

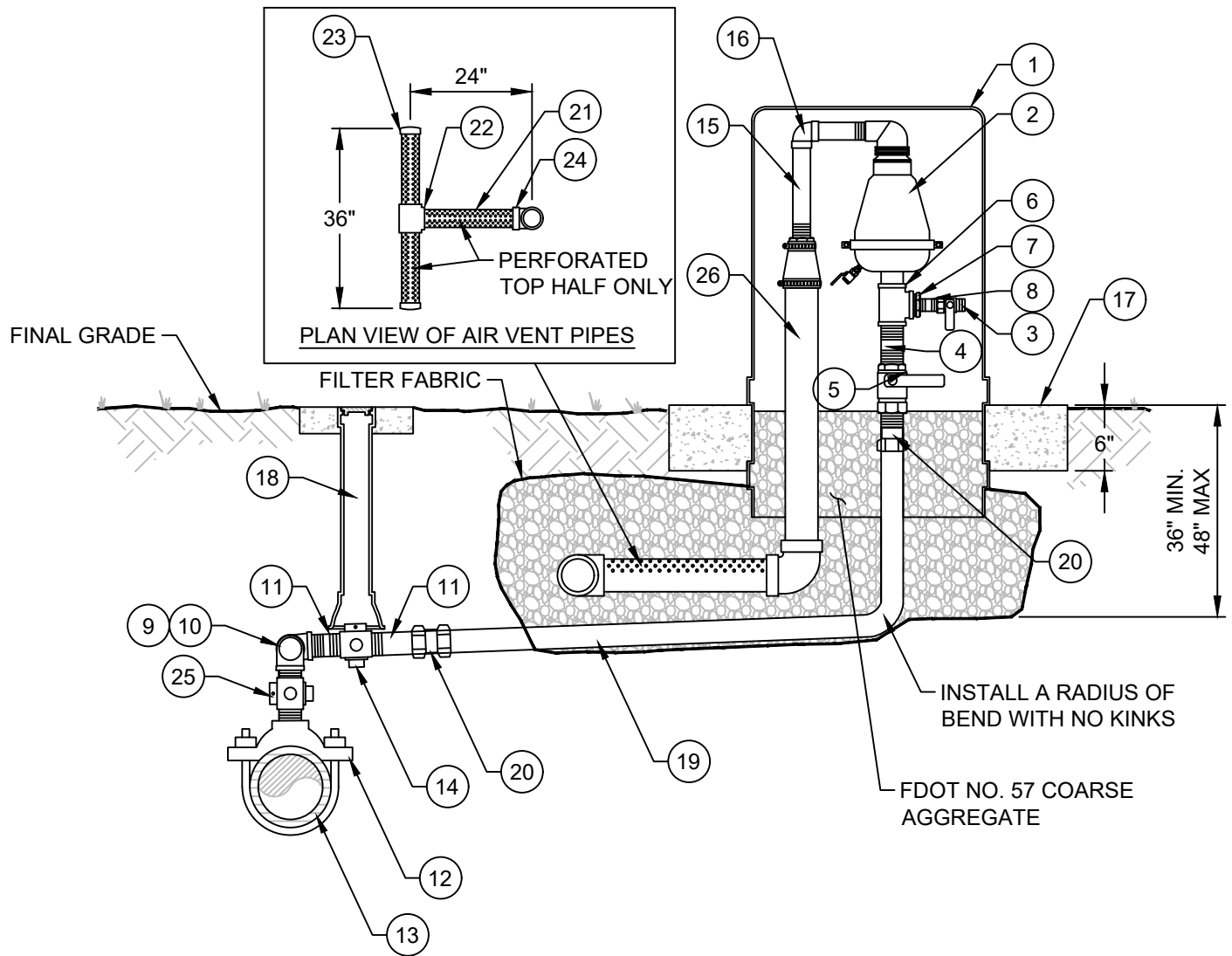

MATERIALS		
ITEM	QUANTITY	DESCRIPTION
1	1	ENCLOSURE (PURPLE IN COLOR)
2	1	AUTOMATIC COMBINATION AIR VALVE
3	1	1" CURB STOP - BRASS
4	1	2" x 4" NIPPLE - BRASS
5	1	2" BALL VALVE - BRASS
6	1	2" TEE - BRASS
7	1	2" x 1" BUSHING - BRASS
8	1	1" SHORT NIPPLE - BRASS
9	2	2" 90° ELBOW - BRASS
10	1	2" SHORT NIPPLE - BRASS
11	2	2" PVC PIPE (SCH 80)
12	1	SERVICE SADDLE W/ 2" TAP

13	-	RECLAIMED WATER MAIN
14	1	2" CURB STOP
15	2	1 1/2" PVC (SCH 80) PIPE
16	1	1 1/2" 90° ELBOW - PVC SCH 80
17	1	6" CONCRETE COLLAR AROUND ENCLOSURE
18	1	VALVE COLLAR (SEE DETAIL G-04)
19	1	2" PE TUBING
20	2	2" COMPRESSION FITTING
21	3	3" PERFORATED DRAINAGE PIPE W/ PERFORATIONS ON TOP HALF
22	1	3" PVC TEE
23	2	3" PVC CAP
24	1	3" PVC 90° ELBOW
25	1	2" CORPORATION STOP - BRASS
26	1	3" PVC PIPE

RECLAIMED POND DELIVERY FACILITY CONTROLS NOTES:

THE RECLAIMED WATER POND DELIVERY FACILITY IS DESIGNED TO AUTOMATICALLY SUPPLY RECLAIMED WATER. THE SYSTEM OPERATES AS FOLLOWS:

1. FLOW AND PRESSURE IN THE CITY OF NORTH PORT'S RECLAIMED WATER DISTRIBUTION SYSTEM IS MAINTAINED AT THE CITY'S WATER RECLAMATION FACILITY.
2. RECLAIMED WATER IS DELIVERED TO THE POND AT A RATE GOVERNED BY A MOTOR ACTUATED PLUG VALVE. THE FLOW RATE IS SET AT THE LOCAL CONTROL PANEL OR REMOTELY THROUGH THE SCADA RTU.

NOTES ON 120 V AC FEED TO RECLAIMED POND DELIVERY FACILITY:

1. OBTAIN 120 V AC, 20 AMP CIRCUIT FROM NEARBY 120 V AC SOURCE. DO NOT PROVIDE NEW SERVICE UNLESS NO EXISTING SOURCE OF POWER IS AVAILABLE. PROVIDE TYPE UF FEEDER TO THE RECLAIMED POND DELIVERY FACILITY BY DIRECT BURY 24" BELOW GRADE. PROVIDE METALLIC WARNING TAPE 12" BELOW GRADE.
2. WHERE A NEW SERVICE IS REQUIRED, PROVIDE A SERVICE WITH METER AND 240/120 V AC DISTRIBUTION PANEL. USE ALL-IN-ONE PANEL: SQUARE D TYPE SC1624M100S OR EQUIVALENT WITH 100 AMP MAIN BREAKER AND 20 AMP FEEDER BREAKER TO THE RTU AND CONTROLS.

GENERAL NOTES:

1. ALL WORK SHALL CONFORM TO THE NATIONAL ELECTRIC CODE (N.E.C.), LATEST EDITION. CONTRACTOR SHALL OBTAIN ALL PERMITS AND ARRANGE FOR INSPECTIONS WITH ALL AUTHORITIES HAVING JURISDICTION.
2. CONDUITS, RACEWAYS, AND CABLES SHALL BE PROPERLY AND SECURELY ATTACHED TO STRUCTURAL COMPONENTS AS REQUIRED BY N.E.C. ALL FASTENERS AND HARDWARE SHALL BE APPROVED FOR THE INSTALLATION AND ALL CONDITIONS ENCOUNTERED. CONDUIT ENDS MUST BE SEALED WITH DUCT SEAL PUTTY OR EQUAL, IN A MANNER THAT IS EASILY REMOVED FOR FUTURE NEEDS.
3. EACH OUTLET OR JUNCTION IN ANY OF THE WIRING SYSTEMS SHALL BE MADE IN AN APPROVED JUNCTION BOX. EACH BOX SHALL BE SUITABLE FOR THE SIZE AND NUMBER OF CONDUCTORS AND DEVICES TO BE INSTALLED, AS WELL AS ANY ADVERSE CONDITIONS ENCOUNTERED. ALL SPLICES SHALL BE MADE WITH APPROVED MECHANICAL CONNECTORS.
4. ALL RACEWAYS SHALL BE PROVIDED WITH CONTINUOUS EQUIPMENT GROUNDING CONDUCTOR. EQUIPMENT GROUNDING SHALL BE INSTALLED IN ALL ELECTRICAL RACEWAYS AND SHALL BE IN ACCORDANCE WITH N.E.C. ARTICLE 250.
5. THE CONTRACTOR SHALL BE RESPONSIBLE FOR FURNISHING, INSTALLATION, TESTING, CALIBRATING, AND OTHERWISE MAKING OPERATIONAL ALL DEVICES AND EQUIPMENT SHOWN ON THESE DRAWINGS. ALL FINAL DRAWINGS AND SOFTWARE, PROGRAMMING SOFTWARE, AND SPECIAL CABLES SHALL BE FURNISHED TO NPU PRIOR TO FINAL COMPLETION.
6. THESE DETAILS ARE DIAGRAMMATIC, BUT SHALL BE FOLLOWED AS CLOSELY AS ACTUAL CONSTRUCTION OF THE PROJECT AND THE WORK OF THE OTHER TRADES WILL PERMIT. THE DRAWINGS UTILIZE SYMBOLS AND SCHEMATIC DIAGRAMS TO INDICATE VARIOUS ITEMS OF WORK. NO INTERPRETATION SHALL BE MADE FROM THE LIMITATION OF SYMBOLS AND DIAGRAMS THAT ELEMENTS NECESSARY TO THE COMPLETE INSTALLATION ARE EXCLUDED. THE ENGINEER SHALL BE NOTIFIED OF DISCREPANCIES, OMISSIONS, CONFLICTS, OR INTERFERENCES WHICH MAY OCCUR BETWEEN VARIOUS DRAWINGS AND SPECIFICATIONS. IF SUCH NOTIFICATION IS NOT RECEIVED, THE INSTALLING CONTRACTOR(S) SHALL BE RESPONSIBLE FOR THEIR INTERPRETATIONS.
7. ALL CONDUIT SHALL BE SCHEDULE 40 PVC BELOW GROUND AND RIGID GALVANIZED STEEL ABOVE GROUND.
8. FUSE 4-20 MA LOOP POWERED CIRCUIT WITH 0.032 AMP FUSES.
9. GROUND INSTRUMENT CABLE SHIELDS AT ONE END ONLY.

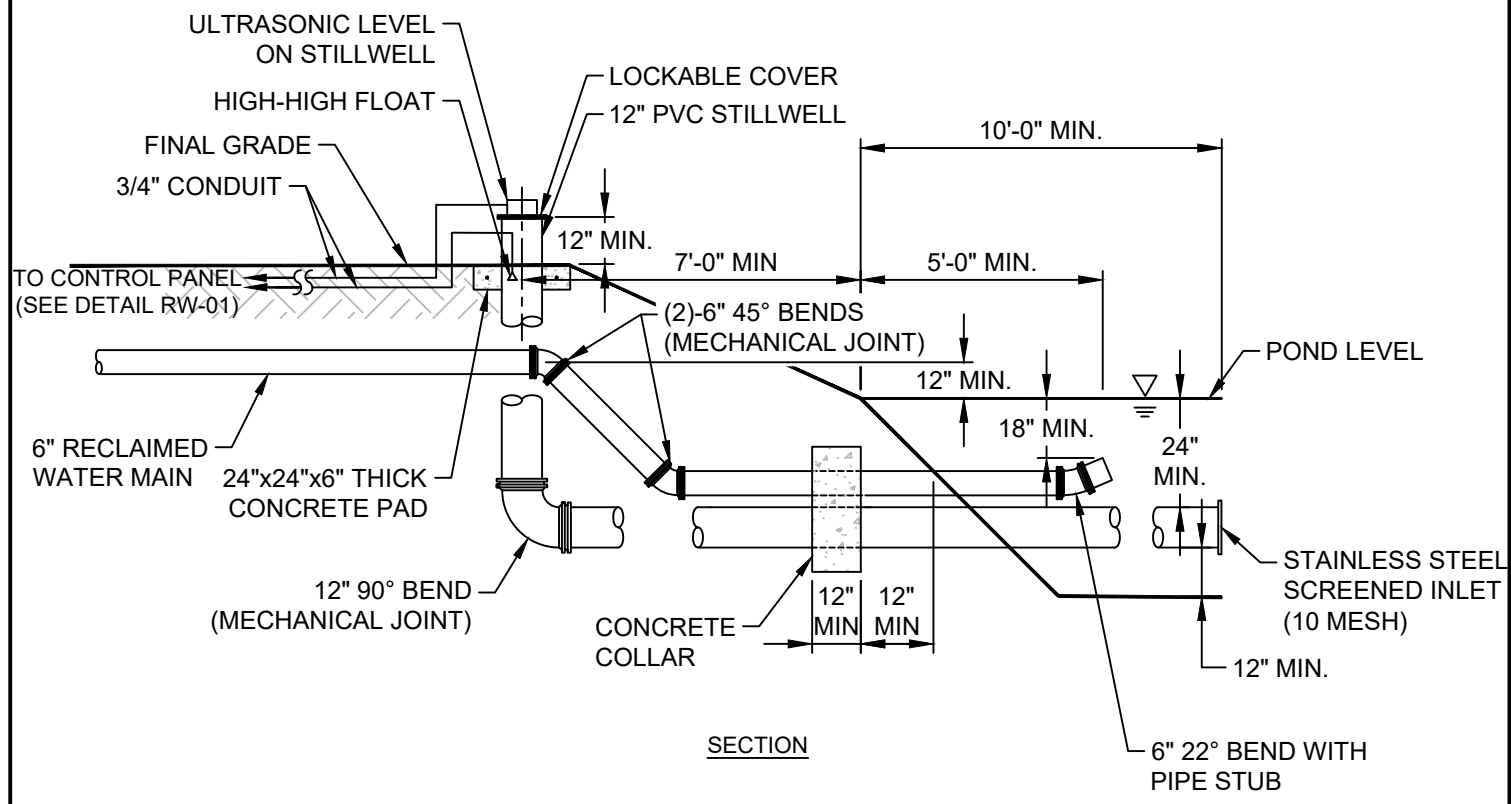
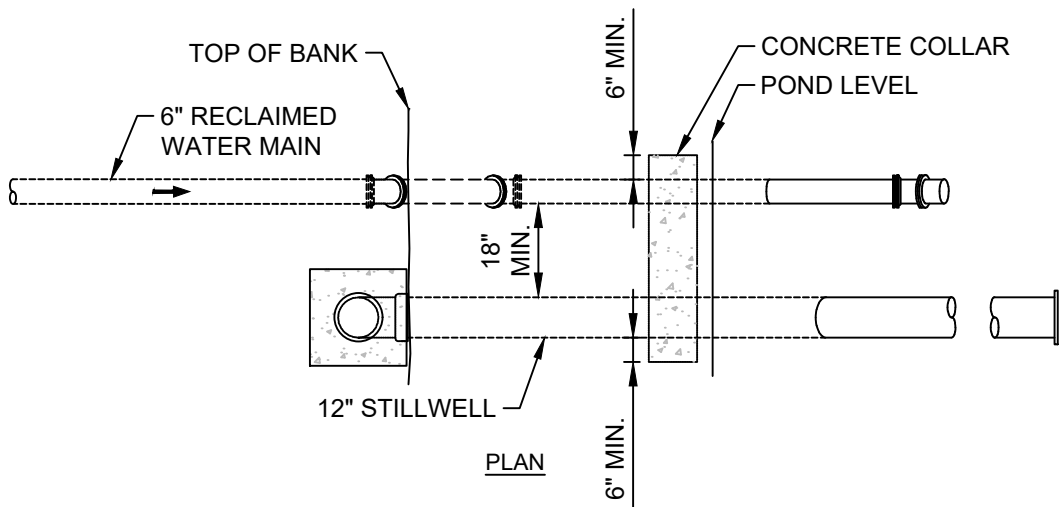

NOTES:

1. CONCRETE SHALL HAVE A MINIMUM COMPRESSIVE STRENGTH OF 2,500 PSI AT 28 DAYS.
2. ALL HARDWARE SHALL BE STAINLESS STEEL.
3. ALL JOINTS SHALL BE RESTRAINED.
4. STILLWELL SHALL BE INSTALLED TRUE AND PLUMB.

reclaimed details.dwg Aug-2020



RECLAIMED POND DELIVERY FACILITY

DETAIL
RW-04
SHEET 1 OF 1

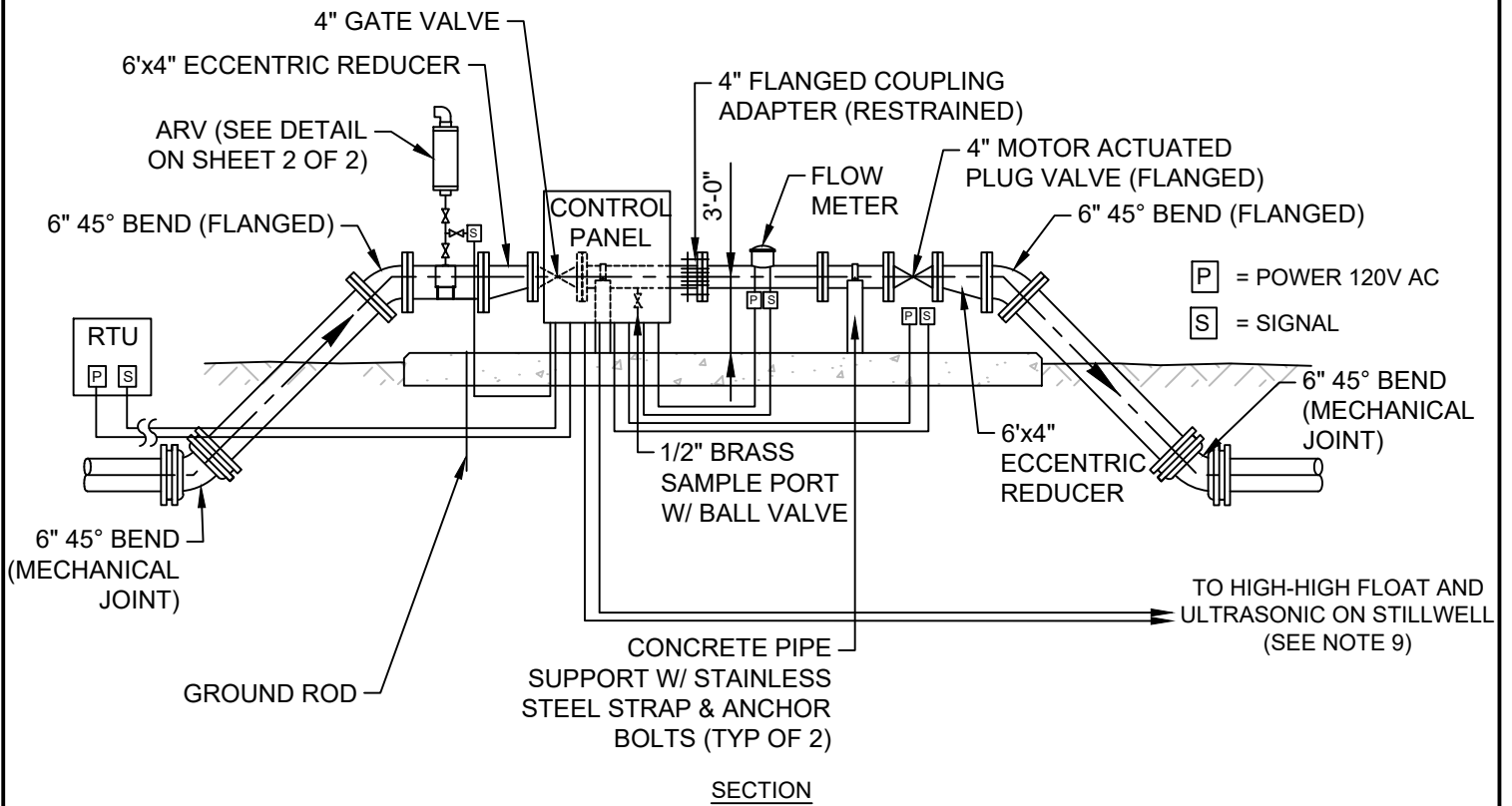
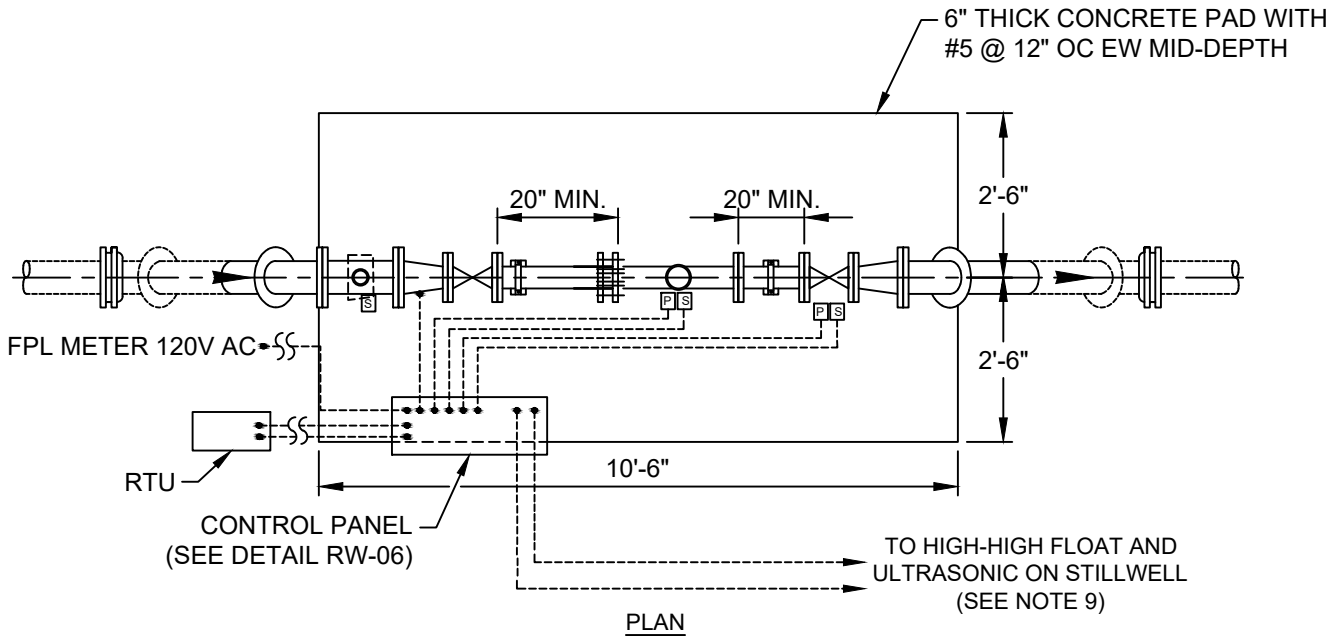

reclaimed details.dwg Aug-2020



RECLAIMED POND DELIVERY FACILITY METER ASSEMBLY

DETAIL

RW-05

SHEET 1 OF 2

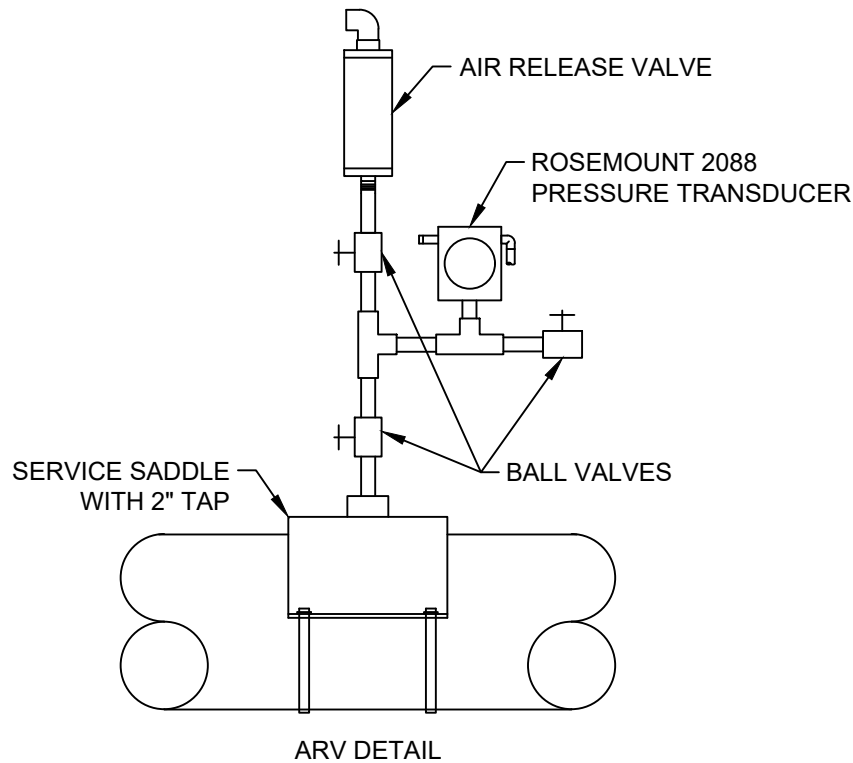

NOTES:

1. ALL AUXILIARY EQUIPMENT AND POWER SUPPLIES SHALL BE SUPPLIED BY THE CONTRACTOR AS REQUIRED TO MAKE RECLAIMED WATER METER ASSEMBLY AND RECLAIMED POND DELIVERY FACILITY FULLY FUNCTIONAL AS INTENDED.
2. ALL HARDWARE SHALL BE STAINLESS STEEL.
3. START-UP SHALL INCLUDE EQUIPMENT FACTORY REPRESENTATIVES TO REVIEW INSTALLATION, MAKE ADJUSTMENTS IN OPERATING PARAMETERS, AND INSTRUCT OWNER'S PERSONNEL IN THE OPERATIONS AND MAINTENANCE OF THE EQUIPMENT.
4. ALL EQUIPMENT THAT IS EXPOSED TO THE WEATHER SHALL BE IN NEMA 4X HOUSING.
5. ALL EXPOSED PIPE, FITTINGS, VALVES, AND NON-GALVANIZED FERROUS METALS TO BE PAINTED IN ACCORDANCE WITH NPU SPECIFICATION SECTION 336040.
6. ALL ABOVE GROUND PIPE AND FITTINGS SHALL BE DUCTILE IRON.
7. THE LOCATION OF THE METER ASSEMBLY SHALL BE DETERMINED BY OWNER.
8. RECLAIMED WATER METER ASSEMBLY IS PART OF THE RECLAIMED POND DELIVERY FACILITY. SEE DETAIL RW-02.
9. FOR DIRECT FEED, DELETE STILLWELL AND HIGH FLOAT ULTRASONIC REQUIREMENT AND ASSOCIATED WIRING TO CONTROL PANEL.
10. CONTRACTOR SHALL BE RESPONSIBLE FOR FURNISHING, INSTALLATION TESTING, CALIBRATING, AND OTHERWISE MAKING OPERATIONAL ALL DEVICES AND EQUIPMENT SHOWN ON THIS DETAIL. ALL FINAL DRAWINGS AND SOFTWARE, PROGRAMMING SOFTWARE, AND SPECIAL CABLES SHALL BE FURNISHED TO NPU.
11. CONCRETE SHALL HAVE A MINIMUM COMPRESSIVE STRENGTH OF 2,500 PSI AT 28 DAYS.
12. SUBGRADE BELOW CONCRETE PAD SHALL BE COMPACTED TO MINIMUM 98% AS DETERMINED BY FDOT 1-T 180. SUBGRADE MATERIAL SHALL BBE CRUSHED STONE PER NPU SPECIFICATIONS SECTION 311030. MINIMUM THICKNESS SHALL BE 6".

reclaimed details.dwg Aug-2020

PEDESTAL MOUNTED TYPE 316 STAINLESS STEEL, NEMA 4X CABINET W/ SUN SHADE AND LOCKING CLOSURE ON 3' HIGH x 2-1/2" STAINLESS STEEL SCH 40 PIPE STAND WITH 125# FLANGE BASE BOLTED TO CONCRETE PAD W/ 3/8" STAINLESS STEEL ANCHOR BOLTS

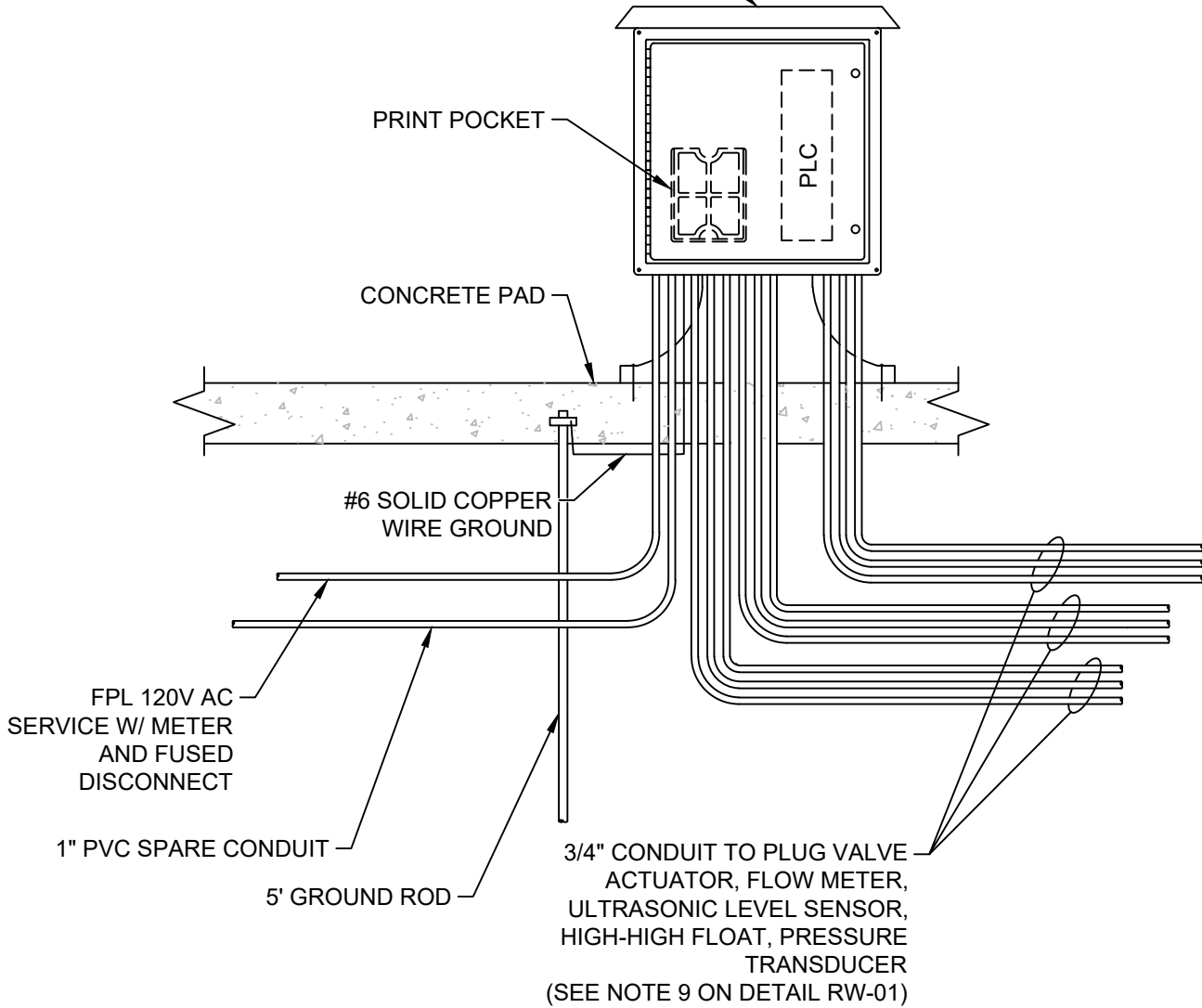

CONTROL PANEL NOTES:

1. CONTROL PANEL SHALL HOUSE UPS, RELAY LOGIC, PID FUNCTION CONTROL, SURGE EQUIPMENT FOR ANALOG I/O, AND MAIN POWER ENTRY.
2. INCLUDE INDICATION FOR FLOW, PRESSURE, VALVE POSITION, VALVE SET POINT, AND LOCAL/REMOTE LEVEL.

ELECTRICAL CONDUIT NOTES:

1. ALL CONDUIT FITTINGS WILL BE WATERTIGHT AND SEALED WITH SILICONE ON THE SENSOR SIDE.
2. THE CONDUIT RUN TO FUTURE USE IS TO BE SEALED WITH DUCT SEAL PUTTY.
3. ALL ELECTRICAL CONDUIT SHALL BE BURIED 24" BELOW FINAL GRADE.
4. ALL CONDUIT SHALL BE SCHEDULE 40 PVC BELOW GROUND AND RIGID GALVANIZED STEEL ABOVE GROUND.

reclaimed details.dwg Aug-2020



RECLAIMED POND DELIVERY FACILITY CONTROL PANEL

DETAIL

RW-06

SHEET 1 OF 1

reclaimed details.dwg Aug-2020



RECLAIMED POND DELIVERY FACILITY RTU CONTROL PANEL

DETAIL

RW-07

SHEET 1 OF 2

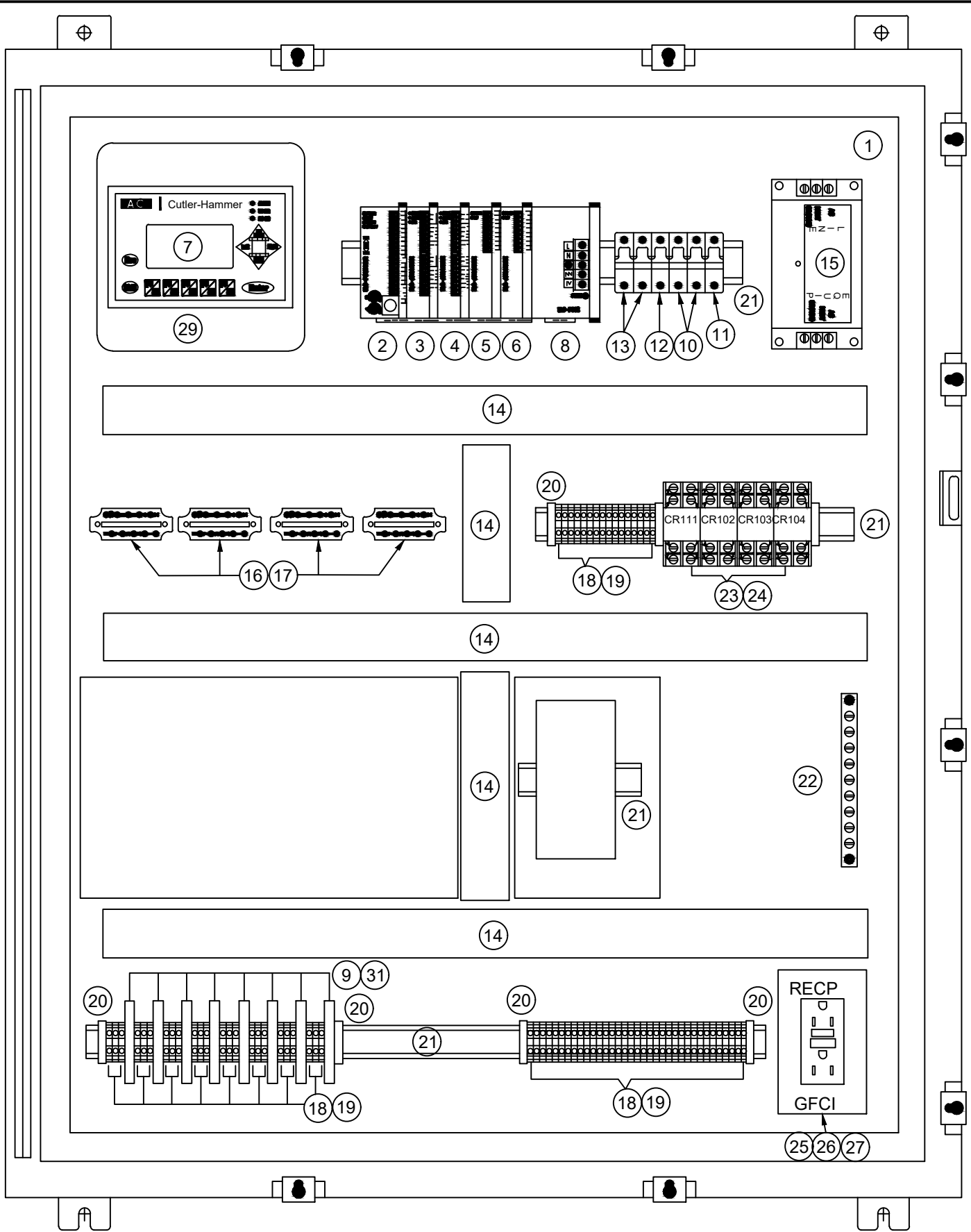

BILL OF MATERIAL

ITEM	QTY.	MANUFACTURER	PART NUMBER	DESCRIPTION
1	1	HOFFMAN		TYPE 316 STAINLESS STEEL, NEMA 4X CABINET, 36"H x 30"W x12"D W/SUN SHADE, SUBPANEL, AND PADLOCK KIT
2	1	EATON	ELC-PC12NNAR	PROCESSOR w/RS232 & RS485 MODBUS-RTU
3	1	EATON	ELC-AN04ANNN	4 ANALOG INPUT
4	1	EATON	ELC-AN04NANN	4 ANALOG OUTPUT
5	1	EATON	ELC-EX08NNAN	8 DIGITAL INPUT, 120 VAC
6	1	EATON	ELC-EX08NNNR	8 RELAY OUTPUT
7	1	EATON	GP-04	GRAPHICAL DISPLAY w/FUNCTION BUTTONS RS-485
8	1	EATON	ELC-PS02	24VCD POWER SUPPLY 2 AMPS
9	8	IMO	ERF3LD24DC	REMOVABLE FUSE-HOLDER, 5x20mm
10	2	CHINT	NB1-B6-1P	CIRCUIT BREAKER, B CURVE, 6A
11	1	SQUARE D	9080GCB150	CIRCUIT BREAKER, 1 POLE, 250 VAC, 15 AMP
12	1	CHINT	NB1-B2-1P	CIRCUIT BREAKER, B CURVE, 2A
13	2	CHINT	NB1-B1-1P	CIRCUIT BREAKER, B CURVE, 1A
14	A/R	PANDUIT	TYPE F	WIRE DUCT, WHITE, NON-SLIP COVER
15	1	EDCO	HSP121BT-1RU	SURGE SUPPRESSOR, 120 VAC
16	4	EDCO	PC642C-036X	SURGE SUPPRESSOR, ANALOG SIGNAL
17	4	EDCO	PC-B1B	SURGE SUPPRESSOR, BASE
18	79	WEIDMULLER	1020100000	PASS THROUGH TERMINAL BLOCK, BOX LUGS, 30 AMPS, WDU 4
19	A/R	WEIDMULLER	1050000000	TERMINAL BLOCK ENDPLATE FOR WDU 4 TERMINALS
20	A/R	WEIDMULLER	0383560000	TERMINAL BLOCK END BRACKET TYPE EW 35
21	A/R	SQUARE D		DIN RAIL, 35mm, ZINC PLATED PERFORATED
22	1	SQUARE D	PK9GTA	GROUND BAR KIT (9) TERMINALS
23	4	SQUARE D	8501RS42V20	2 POLE, DOUBLE THROW, 120V DC CONTROL RELAY CR111, CR102, CR103, CR104
24	4	OMRON	PTF08A-E	CONTROL RELAY BASE, DIN RAIL MOUNTED
25	1	ARRO HART	GROUND FAULT RECEPTACLE	GFI DUPLEX RECEPTACLE, 125 VAC, 15 AMP
26	1	RED DOT	D1H31LM	SINGLE GANG BOX
27	1	HUBBLE	S-26	COVER PLATE, GFCI OUTLET, STAINLESS STEEL
28	1	APC		UPS, 750 VA, 120 VAC INPUT
29	1	ALLIED ENCLOSURE	AM664H	6"x6"x4", NEMA 4X, HINGED SCREW COVER, FIBERGLASS
30	1	POWER FIRST	1FD92	14 GAUGE, 3 CONDUCTOR, 15 AMP, 120 V, TYPE SJT, PVC JACKET, NEMA PLUG 5-15P
31	8	BUSSMANN	S500-32-R	32ma FAST ACTING 5x20mm

NOTES:

- ITEMS #28 AND #30 FIT IN ENCLOSURE BOTTOM.



RECLAIMED POND DELIVERY FACILITY
RTU CONTROL PANEL

DETAIL

RW-07

SHEET 2 OF 2

(MAIN SERVICE DISCONNECT)
PROVIDED BY OTHERS

MAIN INCOMING POWER
120V 1 PHASE 60HZ

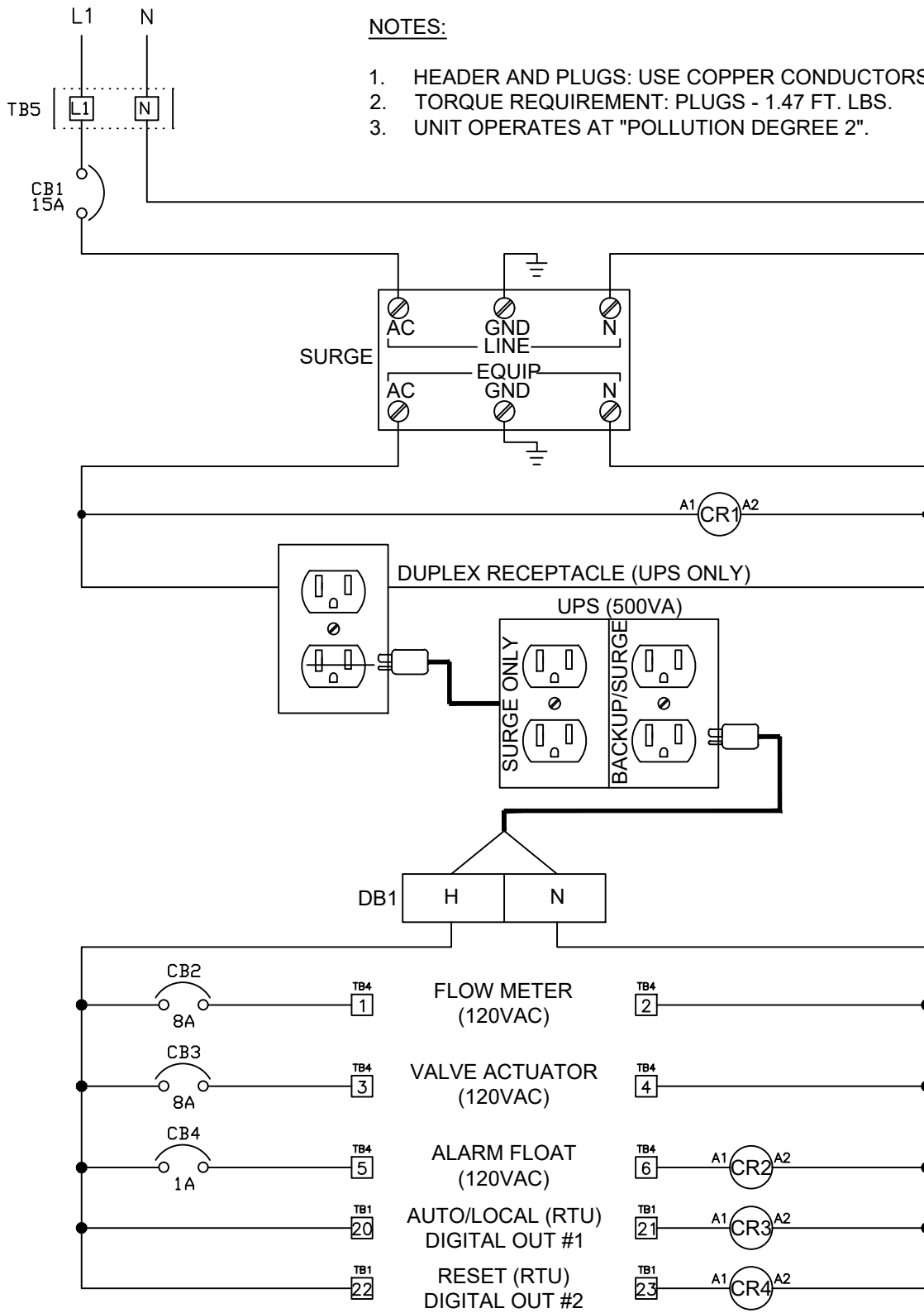

NOTES:

1. HEADER AND PLUGS: USE COPPER CONDUCTORS ONLY.
2. TORQUE REQUIREMENT: PLUGS - 1.47 FT. LBS.
3. UNIT OPERATES AT "POLLUTION DEGREE 2".

reclaimed details.dwg Aug-2020



RECLAIMED POND DELIVERY FACILITY CONTROL SCHEMATIC

DETAIL

RW-08

SHEET 1 OF 5

reclaimed details.dwg Aug-2020

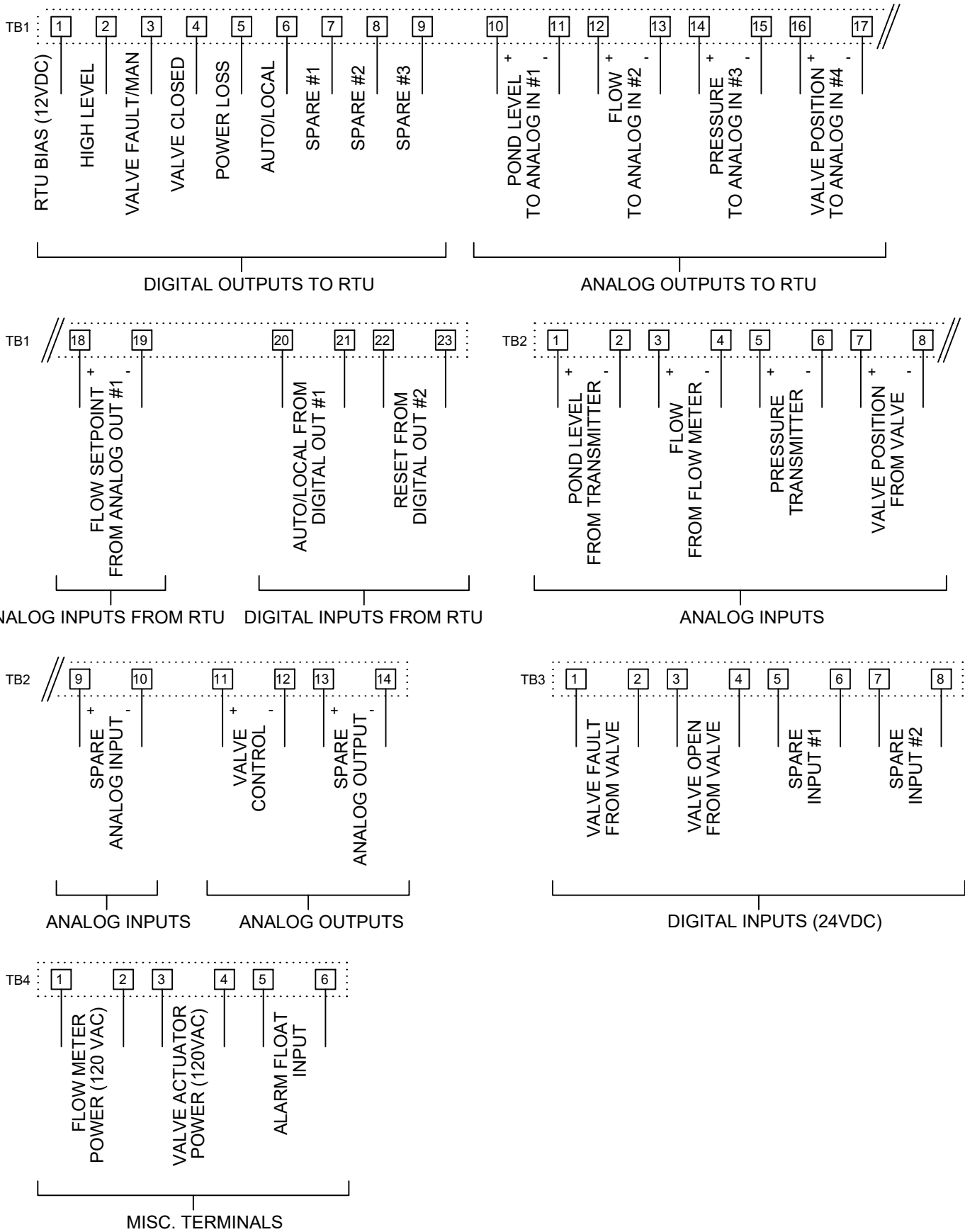

RECLAIMED POND DELIVERY FACILITY CONTROL SCHEMATIC

DETAIL

RW-08

SHEET 2 OF 5

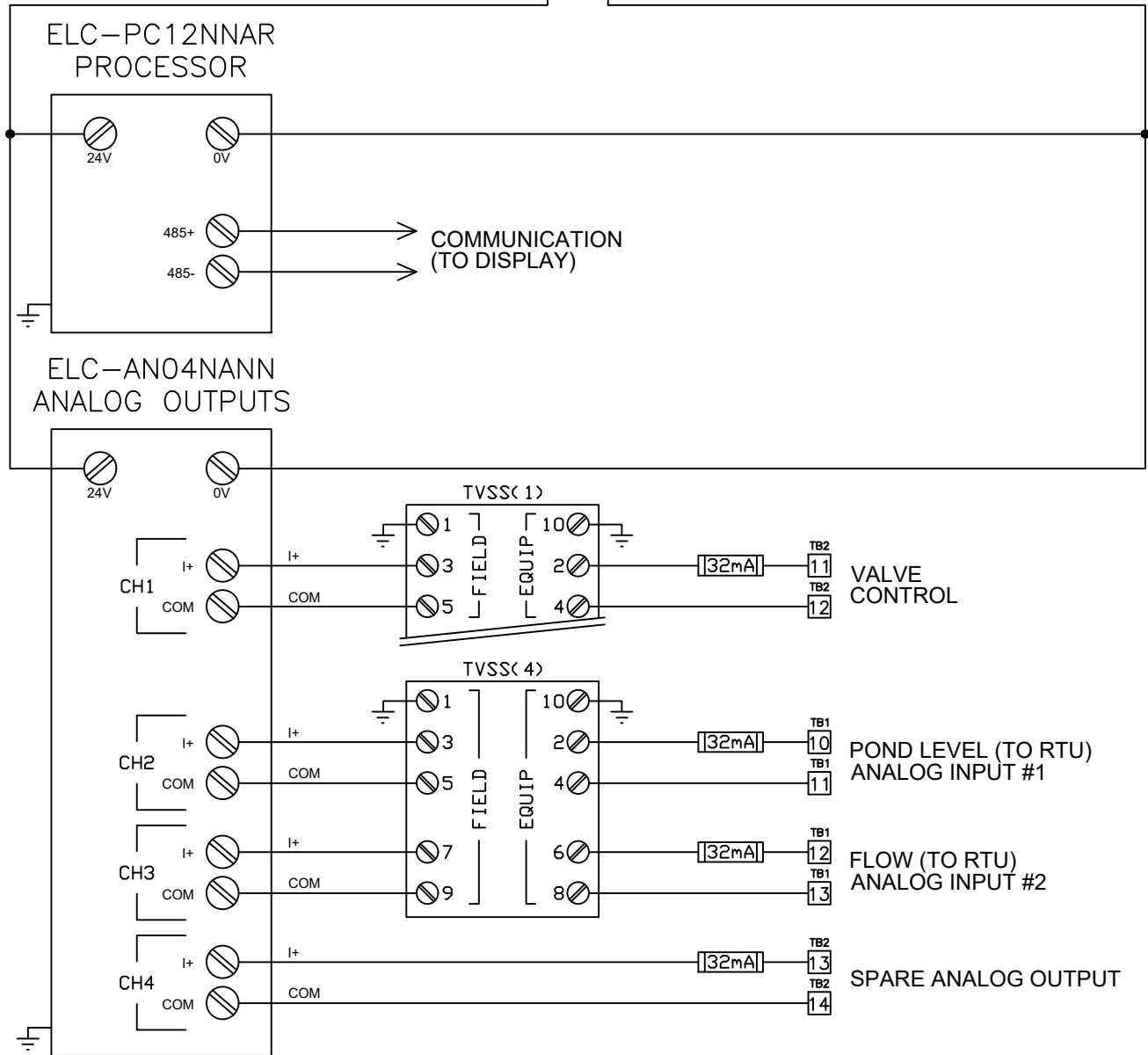
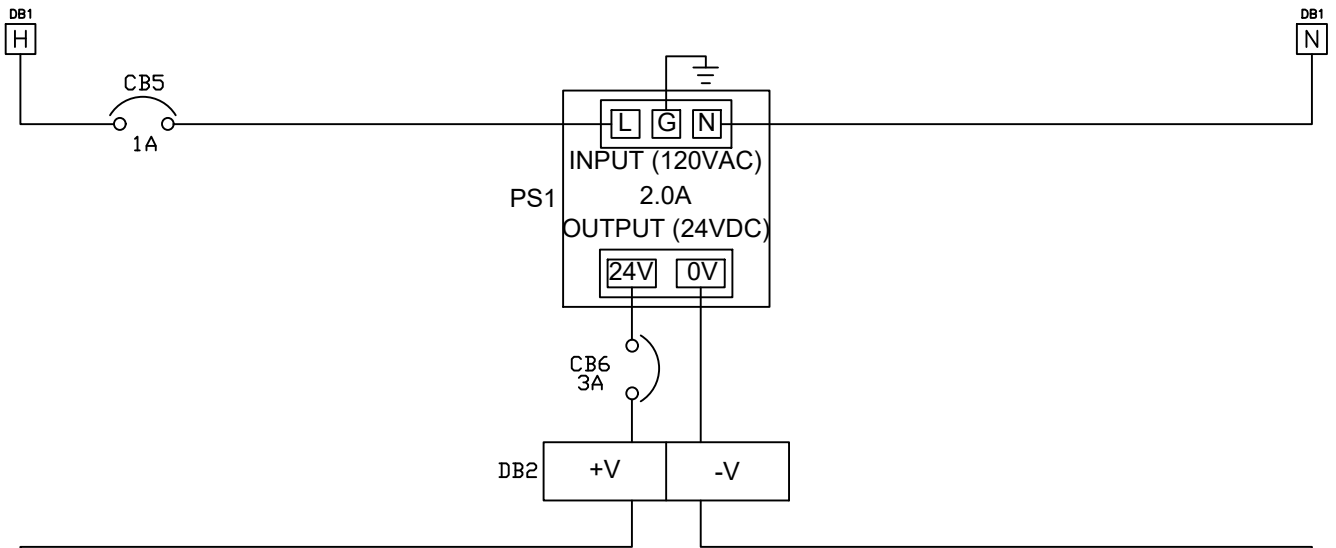

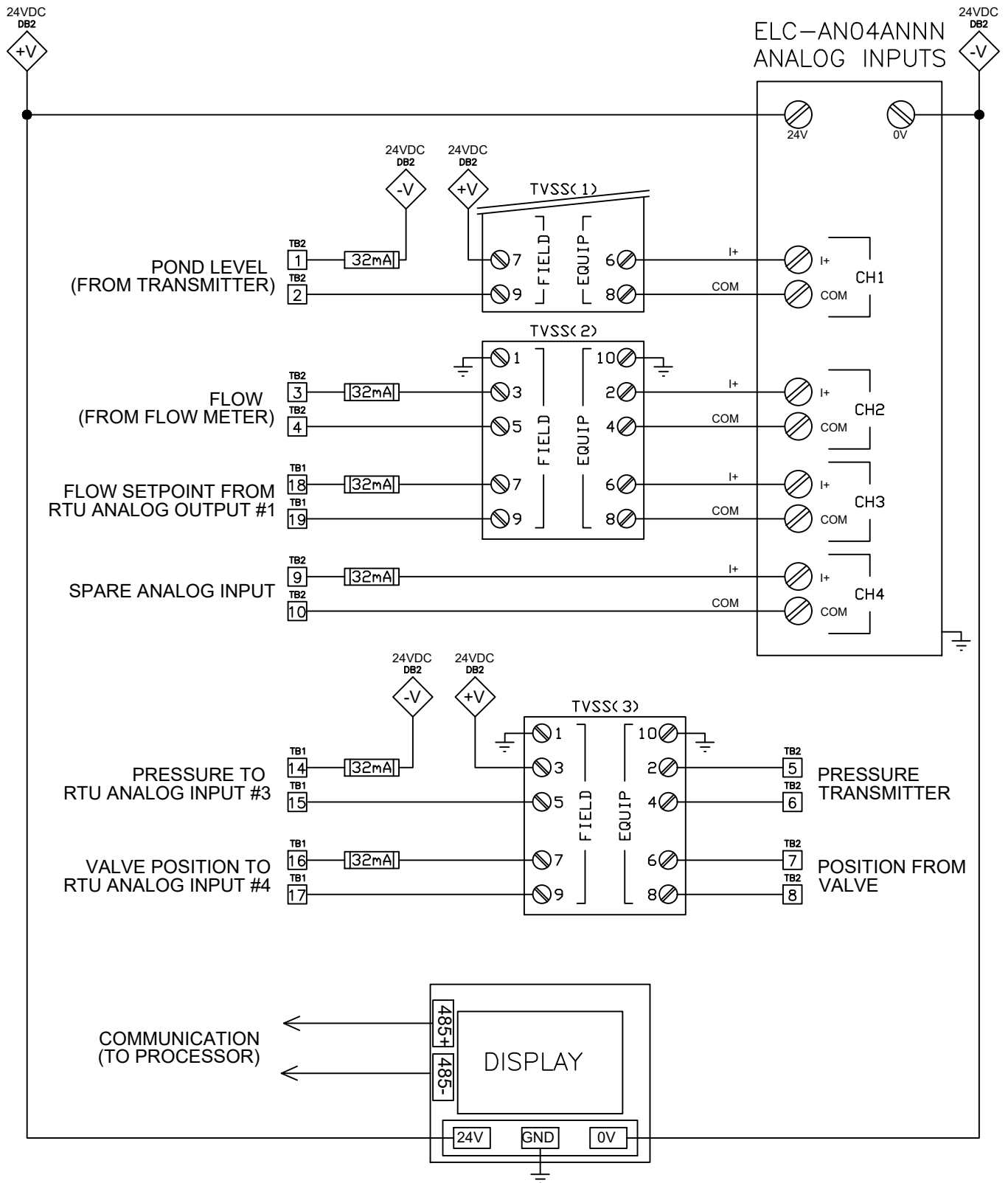

reclaimed details.dwg Aug-2020



RECLAIMED POND DELIVERY FACILITY CONTROL SCHEMATIC

DETAIL

RW-08

SHEET 4 OF 5

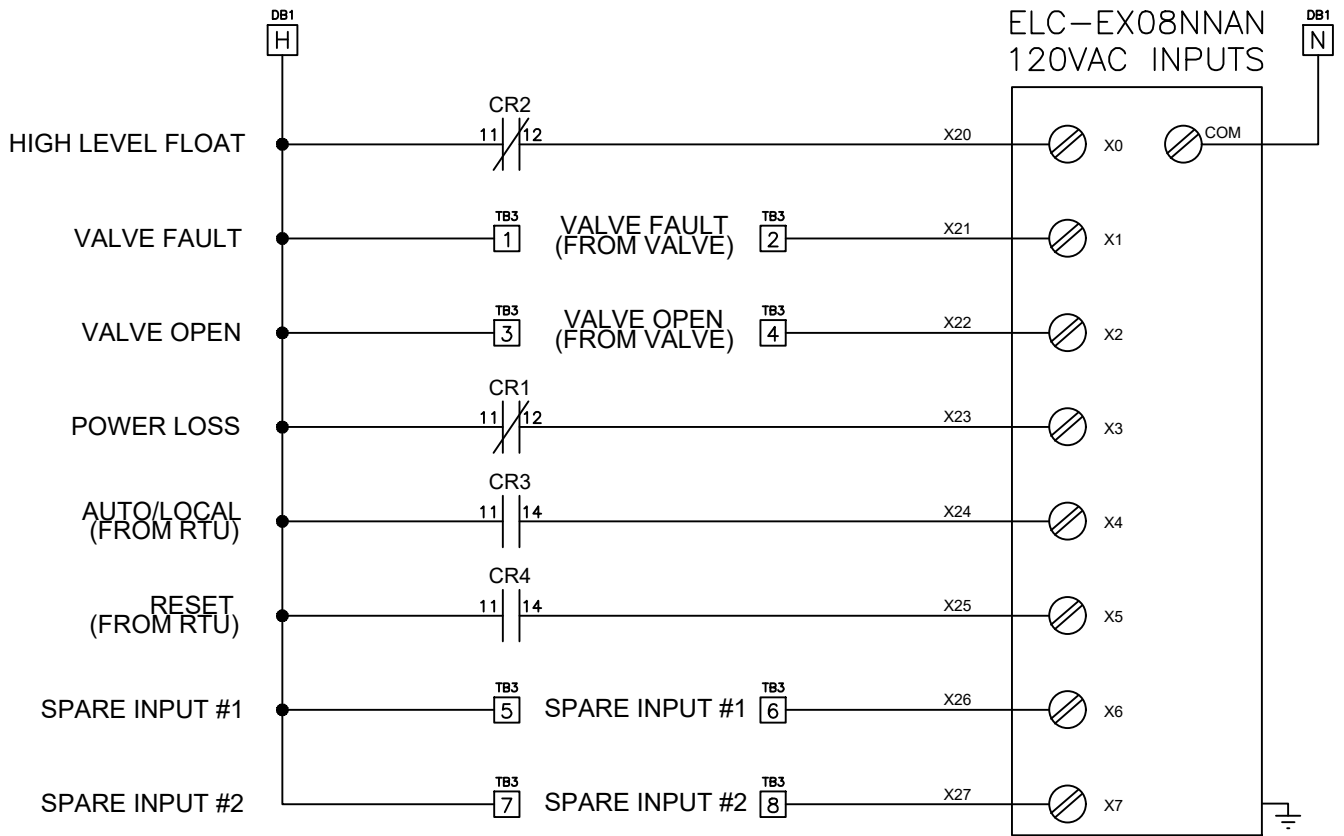

ELC-EX08NNNR
RELAY OUTPUTS

